

THE DAIMLER
Sovereign

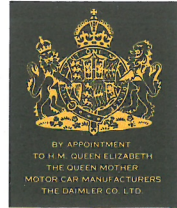



THE DAIMLER 4·2 LITRE

Sovereign

Prestige motoring in the truly modern manner is exemplified in every detail of the elegant and powerful 4.2 litre Daimler Sovereign – a spacious and luxurious five seater saloon – which, in the tradition of its predecessors, provides distinctive quality and refinement in a car of outstanding performance and character.







Sovereign luxury

Sovereign luxury is a combination of silent, effortless power and the most comprehensive of specifications which includes all-round independent suspension, varying-ratio power steering and servo-assisted disc brakes on all four wheels. The superb road performance of the Daimler Sovereign is correspondingly matched by its luxurious interior refinement, which provides the utmost comfort for driver and passenger alike. Upholstery is in ventilated leather hide

of the finest quality. Front seats have combined height and reach adjustment and reclining squabs. Central folding armrests front and rear. Deep pile carpets over thick felt underlay fitted throughout. Adjustable length steering column. Comprehensive instrumentation and finger tip control switches in an attractive walnut panel with protective surround incorporating transistorised clock. Padded door cappings, parcels shelf and sun visors. High efficiency heating and demisting system. Electrically heated rear window. Door pockets front and rear. All these features, and the many others itemised in the specification data at the rear of this brochure, are fitted as standard equipment in the Sovereign.



all the luggage you'll ever need . . .

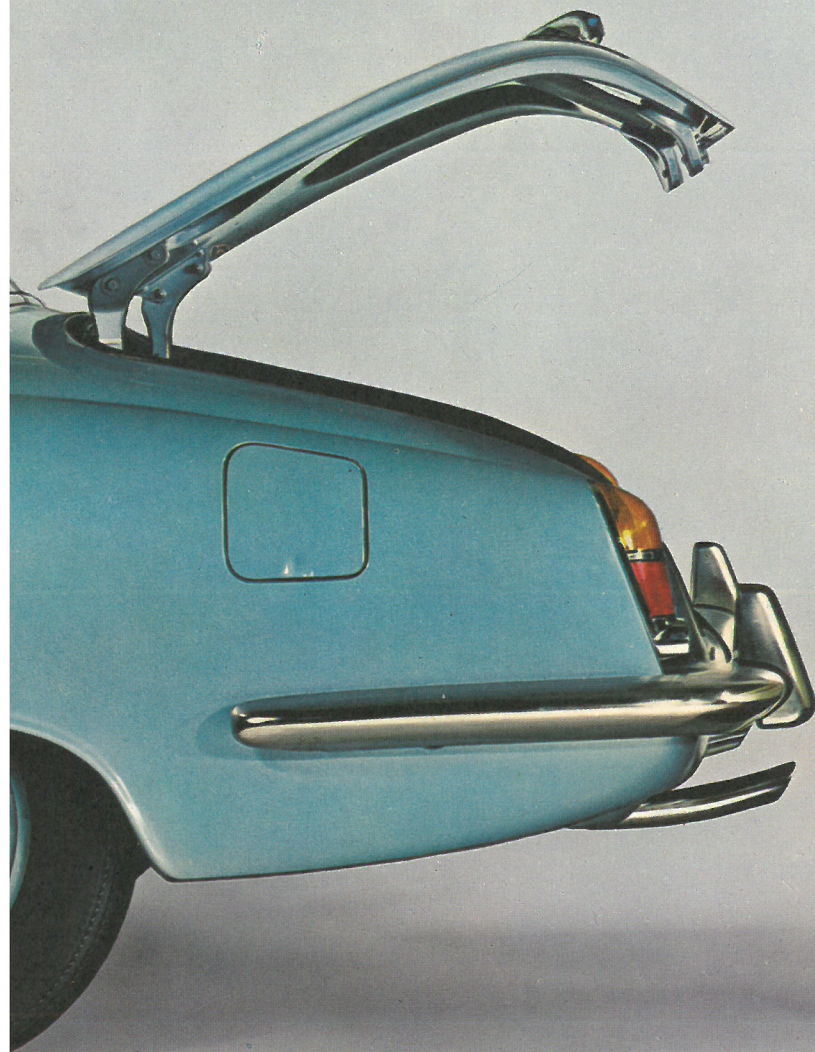

The wide and long boot of the Daimler Sovereign provides no less than 19 cubic feet usable capacity, which accommodates with ease the luggage of five people. It is fully trimmed throughout and is illuminated at night. Spare wheel and tools are carried in a separate compartment beneath the luggage boot floor.

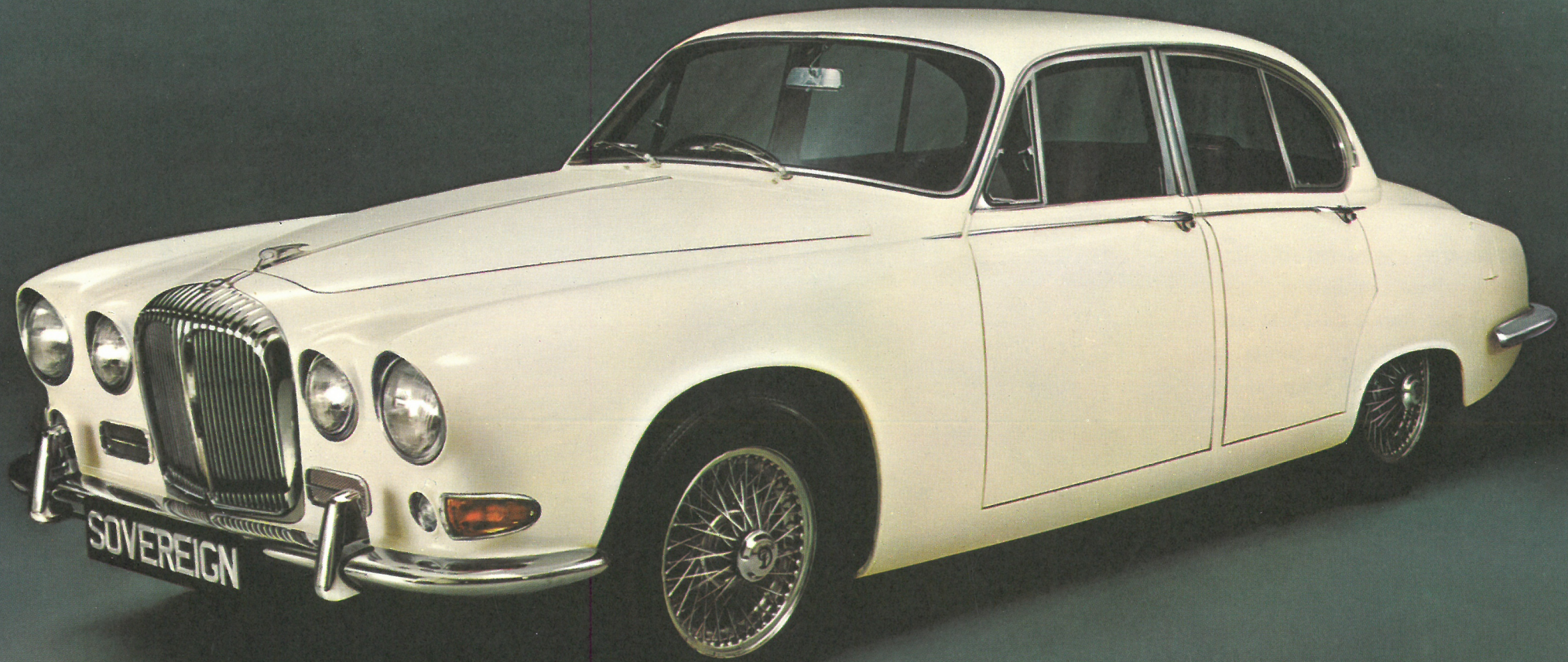

serenely smooth power

The superbly engineered six cylinder, twin overhead camshaft engine with twin carburetters is a 4.2 litre version of the famous 'XK' power unit which develops 245 b.h.p. and 282 lb./ft. torque, thus providing high rates of acceleration and extremely flexible top gear performance throughout the speed range. It is renowned for its consistency of performance and for its ability to run extraordinary mileages with complete reliability.

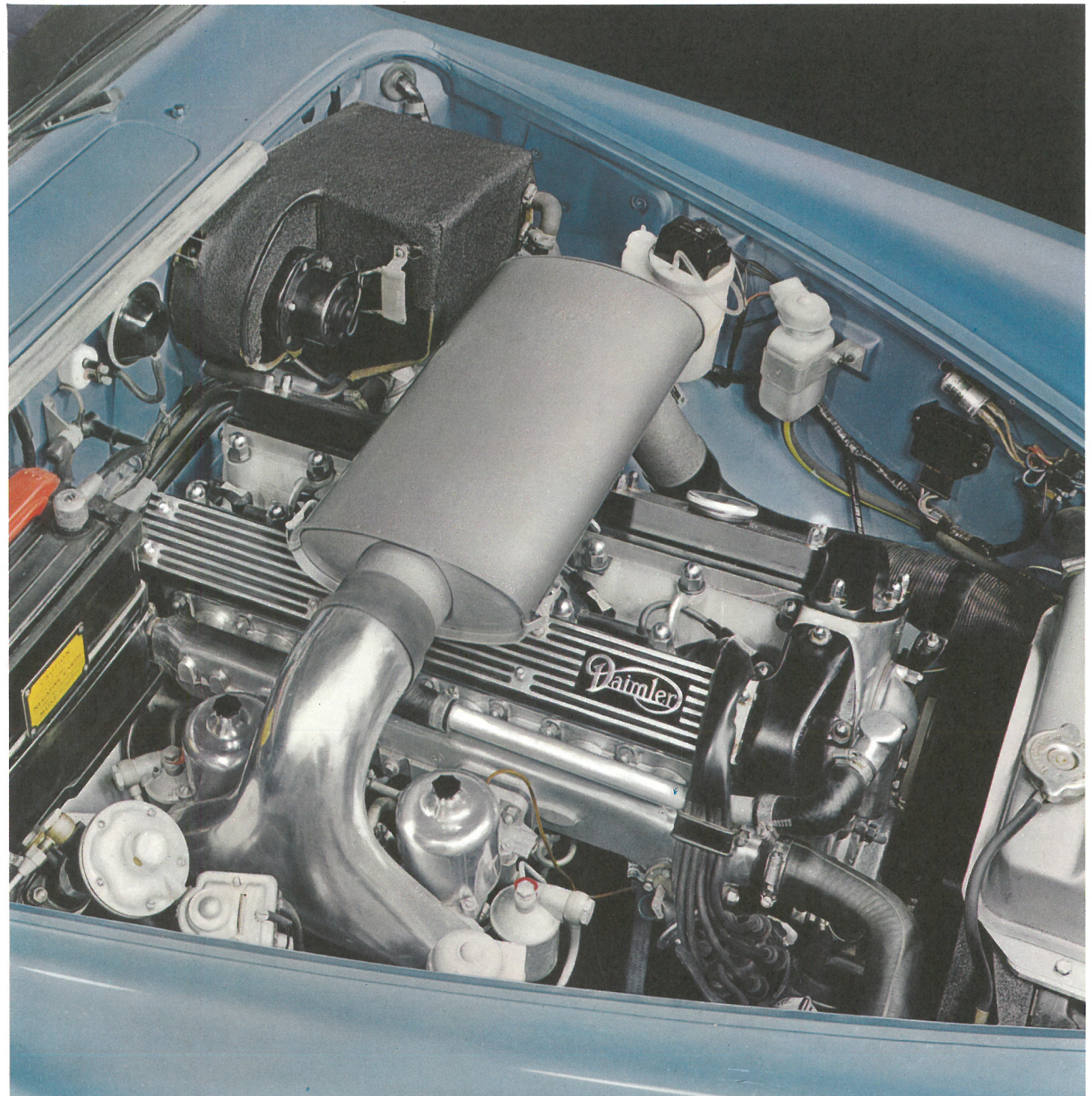

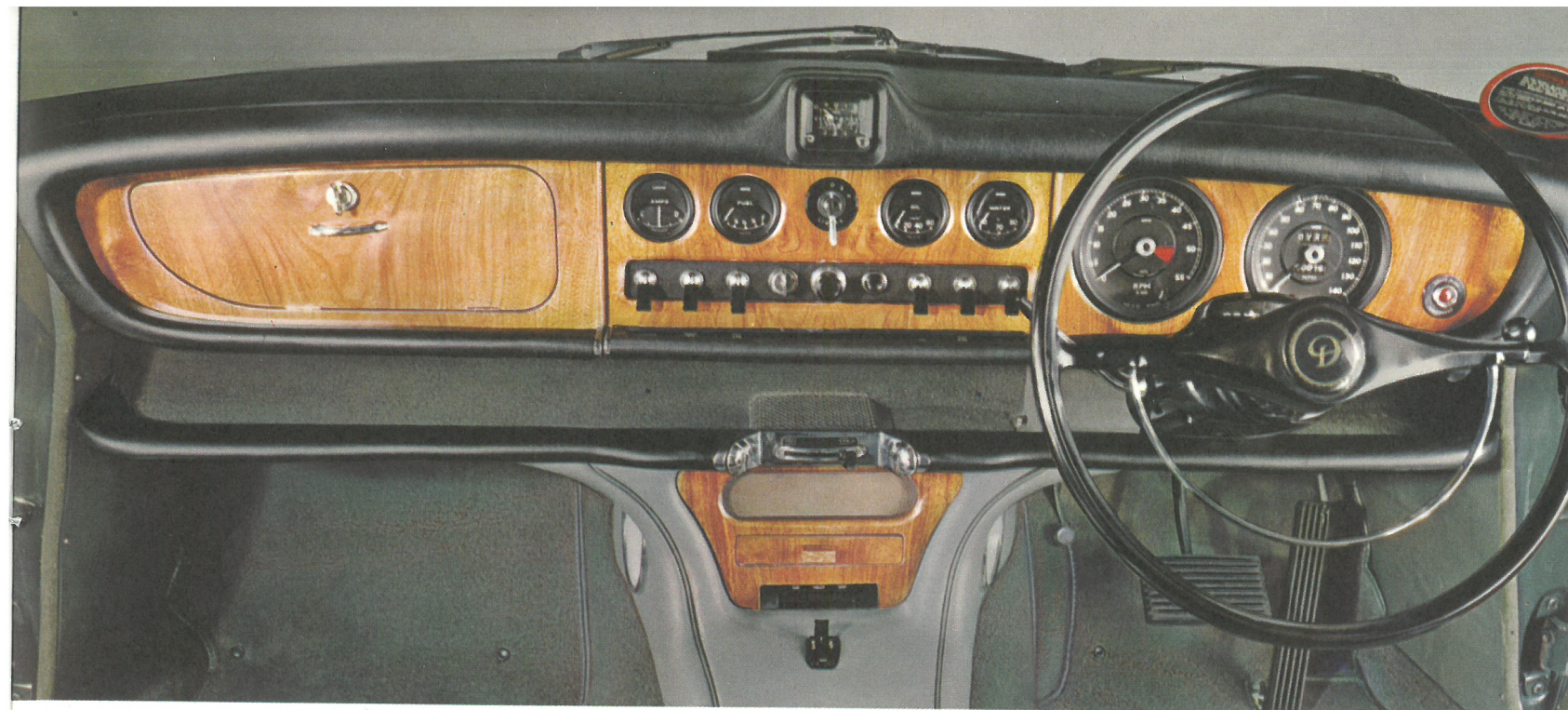

A comprehensive array of instruments and finger tip control switches is incorporated in an attractive polished walnut panel with a protective padded surround which features a transistorised electric clock.

The telescopically adjustable steering column, together with the variable reach of the reclinable front seats, enables every driver to select the most comfortable driving position. The gear lever is ideally placed for ease of operation from every driving position.



features of the Daimler Sovereign

- 1 Fully rust and sound-proofed body, finished to the highest standards.
- 2 Reclining front seats, with combined height and reach adjustment.
- 3 Finest quality ventilated leather hide upholstery for front and rear seats, each incorporating central folding armrests.
- 4 Deep pile carpets with thick felt underlay.
- 5 Screen rail, instrument panel and parcel shelf surrounded by protective padding. Zone toughened windscreen.
- 6 'Varamatic' varying ratio power steering fitted as standard. Adjustable length steering column.
- 7 Comprehensive instrumentation, including impulse driven revolution counter, transistorised electric clock and combined handbrake and brake fluid level warning light. Rear view mirror incorporates dimmer control.
- 8 Door pockets in all four doors, and full width parcels shelf beneath fascia.
- 9 19 cu. ft. luggage compartment with trimmed interior. The spare wheel and tool kit, which is in a specially fitted and lined container, are housed in a separate yet easily accessible compartment beneath the luggage boot floor.
- 10 High efficiency fresh air heating and demisting system capable of high temperature and volume supply to front and rear compartments. Direction control for each side of front compartment, separate control for rear compartment, two-speed fan, and vacuum servo operated air intake vent and heater valves are features of this system.
- 11 4.2 litre, 6 cylinder, twin overhead camshaft engine with twin carburettors gives high rates of acceleration and extremely flexible top gear performance throughout the speed range.
- 12 High efficiency cooling system with viscous coupling fan for reduced power absorption.
- 13 Alternator generator for high output, particularly at low engine speeds.
- 14 Automatic choke, which, with pre-engaged starter, ensures cold weather starting efficiency.
- 15 Choice of transmission—fully automatic with dual drive range, or all synchromesh manual with or without overdrive.
- 16 Fully independent suspension on all four wheels.
- 17 SP41 radial ply tyres fitted as standard.
- 18 Servo-assisted self-adjusting disc brakes with separate hydraulic circuits to front and rear brakes. Self-adjusting handbrake operating on rear wheels.
- 19 Four headlamp lighting system with flashing control.
- 20 Twin reversing lamps.
- 21 Twin fuel tanks, one in each rear wing, with 14 gallons total capacity.
- 22 Twin exhaust system with aluminised multi-silencers.
- 23 Electrically heated rear window fitted as standard.

OPTIONAL EXTRA FEATURES: Full air conditioning equipment. Radio with remote control aerial. Fog lamps. Wire wheels. Rear seat belts. Laminated windscreen. Anti-theft steering lock.

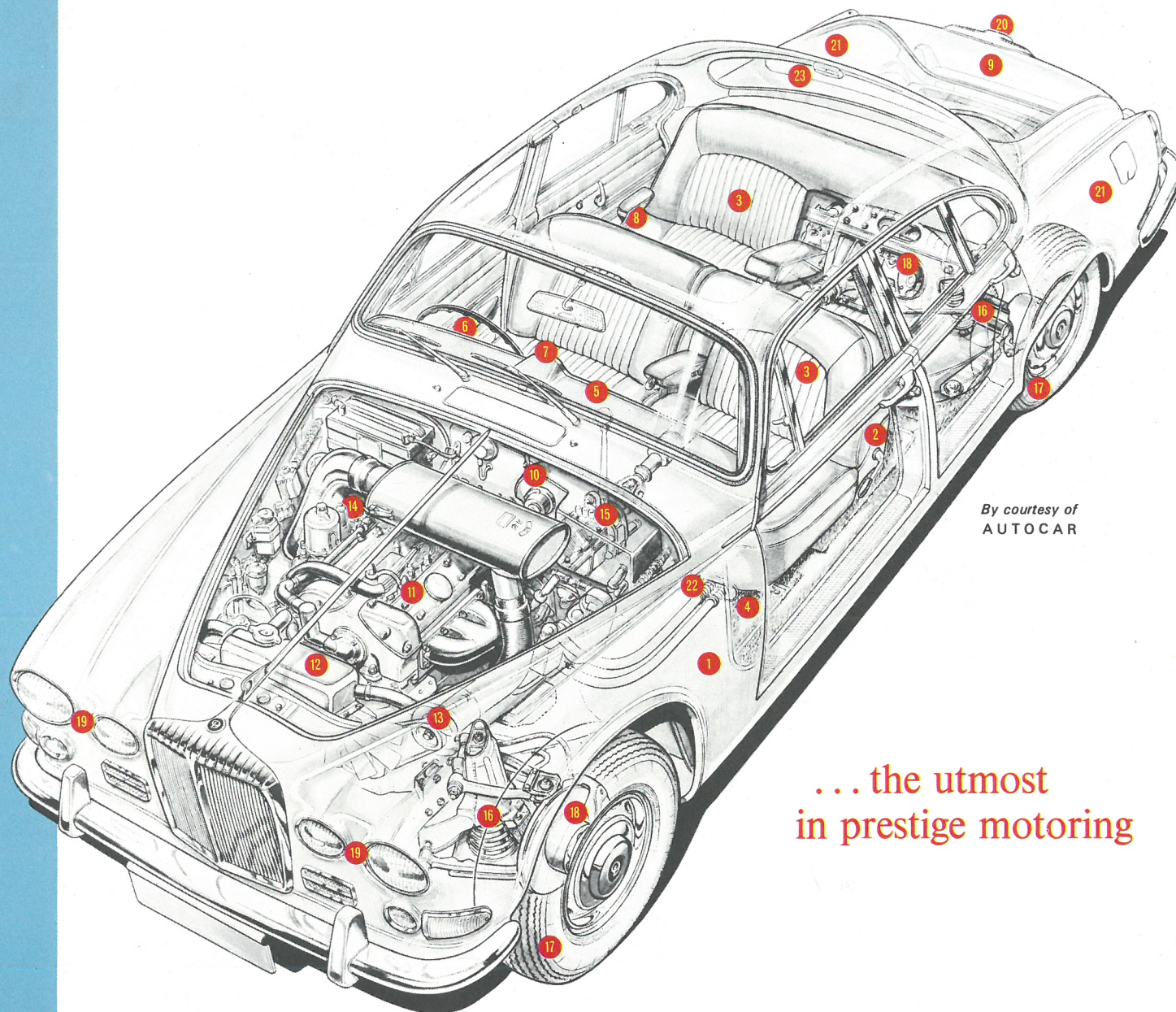

By courtesy of
AUTOCAR

... the utmost
in prestige motoring

THE DAIMLER SOVEREIGN SPECIFICATION

ENGINE. 6 cylinder, twin overhead camshaft, 4.2 litre engine, 92.07 mm. bore \times 106 mm. stroke (3.625 in. by 4.1732 in.). Cubic capacity 4235 c.c. (258.43 cu. in.). Compression ratio 8 : 1. Power output 245 b.h.p. at 5,500 r.p.m. Torque 282 ft./lb. at 3,750 r.p.m. Twin S.U. carburettors, type HD.8, with automatic starting control. Forced lubrication incorporating a full flow filter. Chrome iron cylinder block fitted with dry type cylinder liners. Special "straight port" cylinder head of high tensile aluminium alloy featuring hemispherical combustion chambers and twin overhead camshafts operating large valves of 70° included angle. Aluminium alloy pistons. Steel connecting rods fitted with lead indium big-end bearings. 2 $\frac{3}{4}$ in. diameter counterweighted crankshaft carried on seven large lead indium bearings. Pressurised cooling system with thermostatic control and viscous coupling fan.

TRANSMISSION. (Manually operated gearbox with overdrive.) Four-speed single helical all synchromesh gearbox with Laycock de Normanville overdrive. Gear change lever on floor between front seats. Overdrive controlled by a lever mounted on the steering column. Gear ratios; 1st, 11.46; 2nd, 7.44; 3rd, 5.00; Top, 3.77; Overdrive, 2.93; Reverse, 13.16. Borg and Beck diaphragm spring clutch with hydraulic operation. Needle bearing propeller shaft. Hypoid rear axle with limited slip differential.

TRANSMISSION. (Automatic Transmission model.) Borg Warner Model 8 automatic transmission with dual drive range D1/D2. Gear ratios; Top, 3.54/— with torque conversion 7.08; Intermediate, 5.16/10.32; Low, 8.5/17.0; Reverse, 7.08/14.16. Gear selector on steering column. Needle bearing propeller shaft. Hypoid rear axle with limited slip differential.

SUSPENSION—FRONT. Independent suspension incorporating semi-trailing wishbones and coil springs with telescopic dampers. Anti-roll bar between lower wishbones. Suspension assembly and steering gear are mounted on a separate subframe which is itself located in the body by rubber mountings.

SUSPENSION—REAR. Fully independent rear suspension incorporating on each side a lower transverse tubular link pivoted at the wheel carrier and sub-frame adjacent to the differential case and, above this, a half shaft universally jointed at each end. These serve to locate the wheel in a transverse plane. Longitudinal location is provided by the rubber mountings locating the sub-assembly in the body structure and by a radius arm between the lower link and a mounting point on the body structure. Twin coil springs, each enclosing a telescopic hydraulic damper, provide the suspension medium. The whole assembly together with the differential unit is carried in an easily detachable sub-frame which is located in the body structure by rubber mountings.

BRAKES. Disc brakes, featuring quick change pads, are fitted to all four wheels. Front brakes fitted on wheel hubs, rear brakes fitted inboard of half shafts adjacent to differential unit. System is divided into two entirely independent hydraulic circuits to front and rear brakes. Operation is by suspended vacuum tandem type servo operated by a master cylinder and reaction valve. Handbrake with automatic adjustment operates on rear wheels only. Combined handbrake "on" and brake fluid level warning light.

STEERING. "Varamatic" power-assisted steering. Ratio 21.5 : 1 in straight ahead position varying to 13 : 1 at full lock. 2.75 turns lock to lock. Power supplied by vane pump, incorporating its own fluid reservoir, and driven from front of crankshaft by separate belt. 17 in. diameter two-spoke steering wheel adjustable for reach. Left or right hand steering optional. Turning circle 33 $\frac{1}{2}$ ft.

WHEELS AND TYRES. Pressed steel bolt-on disc wheels fitted with Dunlop SP41 tyres and tubes. Wire spoke wheels available as an optional extra. Spare wheel and tyre.

FUEL SUPPLY. Two separate tanks—one in each rear wing—total capacity 14 gallons. Two electrically operated S.U. fuel pumps (one for each tank) controlled by change-over switch on instrument panel. The separate fillers to each tank are concealed beneath individual covers.

ELECTRICAL EQUIPMENT AND INSTRUMENTS. Lucas alternator 12-volt battery with negative earth system. 60 amp./hour at 10 hour rate with current voltage control. Sidelamps. Four headlamps controlled by foot-operated dip-switch. Separate lever for actuating headlamp flashing. Separate stop/tail, direction and reflector units mounted in a single assembly. Twin reversing lamps. Self-cancelling flashing direction indicators with warning lights. Instruments and labelled switches illuminated by internal lighting controlled by a two-position dimmer switch. Concealed map-reading lamp beneath screen rail in front compartment. Courtesy lights above the centre door pillar and above rear window, operated either manually by switch on the instrument panel or automatically by any of the four doors. Luggage boot illumination controlled by automatic switch. Cigar lighter with luminous socket. Twin-blended windtone horns. Twin blade, two-speed, self-parking windscreen wipers. Electrically operated windscreen washers. Electrically operated back light. Pre-engaged starter motor. Vacuum and centrifugal automatic ignition advance. Oil coil ignition. 5 in. diameter speedometer incorporating total trip and distance recorder. 5 in. diameter impulse driven revolution counter. Separate transistorised time clock centrally mounted in padded screen rail. Ammeter, electrically operated oil pressure gauge, water temperature gauge, fuel gauge, combined handbrake "on" and brake fluid level warning light.

BODY. All steel, four-door, five-seater saloon. Integral body-chassis construction providing maximum rigidity with minimum weight. Large zone-toughened windscreen with slim pillars and semi-wraparound rear window for maximum visibility front and rear. The semi-wraparound windscreen does not interfere with ease of entry or exit. Wide view rear mirror incorporating dimmed image position. Chromium-plated window frames to all doors. Chrome finishers on rain gutters and top of door waist rail. Seats upholstered in finest quality leather hide over deep foam rubber cushions. Front seats have combined height and reach adjustment and reclining squabs. Central folding armrests front and rear. Padded safety screen rail with centrally mounted transistorised time clock. Polished figured walnut instrument panel with heavily padded surround features revolution counter and speedometer positioned directly in front of driver, and separate instruments for oil pressure, water temperature, fuel gauge and ammeter. The panel also contains, on the passenger's side, a glove compartment with interior light and lockable lid. A large padded parcel shelf runs the full width of the car beneath the instrument panel and houses the heater temperature control in its forward edge. A separate housing beneath the instrument panel contains a radio and speaker (optional extra) together with a large ashtray. When no radio is fitted, the speaker grille is retained and the radio control panel aperture is blanked off with an escutcheon. Two-spoke steering wheel and semi-circular horn ring. Front and rear doors incorporate large pockets and armrests, whilst the rear doors also contain ashtrays. Sun visors. Deep pile carpets over thick felt underlay. Heavy duty wraparound bumpers with over-riders. "Zero-torque" door locks enable doors to be closed easily and quietly. Seat belt anchorage points are incorporated for both front and rear seats.

HEATING AND DEMISTING. High efficiency fresh air heating system capable of high temperature and volume supply to front and rear compartments. Separate control regulates supply to rear compartment. Air intake vents and heater valves are vacuum servo assisted. Two-speed fan controlled by switch on instrument panel.

LUGGAGE ACCOMMODATION. Ample luggage accommodation is provided in a capacious compartment of 19 cu. ft. capacity. The lid is counter-balanced for ease of operation. Interior of compartment illuminated by night by a separate lamp. Compartment fully trimmed to protect luggage.

SPARE WHEEL AND TOOLS. The spare wheel is carried beneath the luggage compartment floor in a separate compartment and is readily accessible. The tools, in a special fitted and lined container, are housed in the spare wheel compartment. Jack and wheel brace (or wheel hammer on wire wheel models) housed in luggage compartment.

JACKING. Exterior jacking points, front and rear, enable car to be lifted with the minimum of effort by means of the jack provided.

PRINCIPAL DIMENSIONS. Wheel base 8 ft. 11 $\frac{3}{8}$ in., track front 4 ft. 7 $\frac{1}{2}$ in., track rear 4 ft. 6 $\frac{1}{2}$ in., overall length 15 ft. 7 $\frac{1}{2}$ in., overall width 5 ft. 6 $\frac{1}{2}$ in. Dry weight 3463 lb.

Principal Dimensions

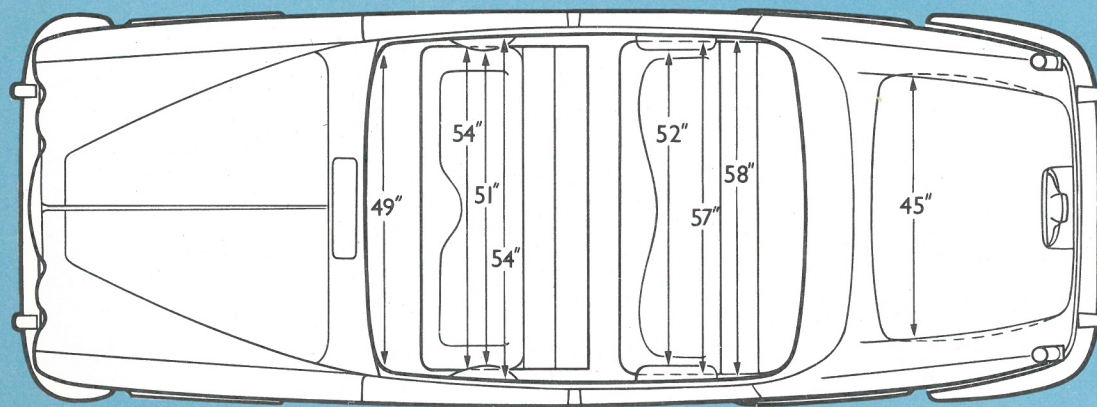
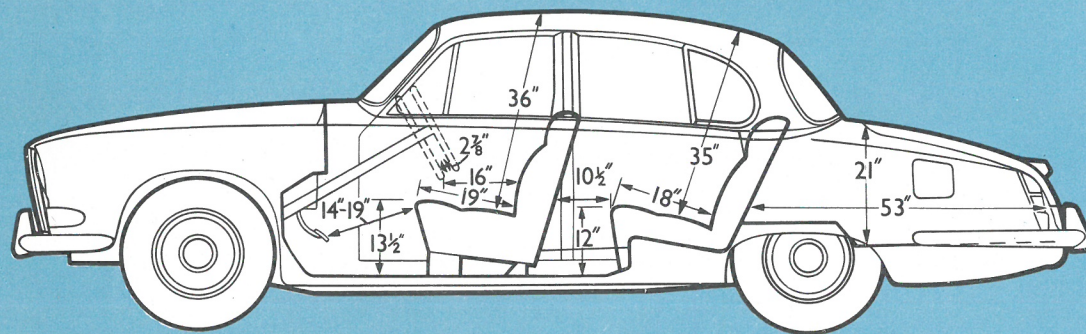

THE DAIMLER COMPANY LIMITED · COVENTRY · ENGLAND

The issue of this catalogue does not constitute an offer. The specification described in this brochure varies for different countries, and The Daimler Company Limited reserves the right to amend specifications at any time without notice.

Colour Schemes

The colour schemes listed below are standard and any deviation involving special treatment of coachwork and/or upholstery will entail extra charge for which a quotation will be given at time of ordering

Coachwork	Interior Colour Alternatives
CREAM	RED, LIGHT BLUE, DARK BLUE
BEIGE	RED, SUEDE GREEN, TAN, LIGHT TAN
WARWICK GREY	RED, DARK BLUE, LIGHT TAN
WILLOW GREEN	SUEDE GREEN, LIGHT TAN, BEIGE, GREY
BRITISH RACING GREEN	SUEDE GREEN, BEIGE, TAN, LIGHT TAN
DARK BLUE	RED, LIGHT BLUE, GREY
BLACK	RED, GREY, TAN, LIGHT TAN
GOLDEN SAND	RED, LIGHT TAN
OPALESCENT SILVER GREY	RED, LIGHT BLUE, DARK BLUE, GREY
OPALESCENT SILVER BLUE	DARK BLUE, GREY
OPALESCENT LIGHT MAROON	MAROON, BEIGE

THE

Daimler

COMPANY LIMITED

The issue of this catalogue does not constitute an offer. The specification described in this brochure varies for different countries, and The Daimler Company Limited reserves the right to amend specifications at any time without notice.

Produced by The Daimler Company Limited, Coventry, England
Printed at The Kynoch Press, Birmingham, England 8.67

Daimler